

Description

This low duty aluminium intrinsically safe switchbox encloses two proximity switches for indicating the fully open and fully closed actuator positions.

The switches are operated by a cam on an extension of the actuator drive shaft and all mechanical parts are contained within the enclosure.

The cams are easily adjustable for quick commissioning.

Cage clamp terminals are pre-wired to the switches which are easily accessible when the top cover is removed. The cover screws are captive.

The switchbox is mounted on top of the actuator with an accessory bracket according VDI/VDE 3845 (NAMUR). Actuators optionally incorporate a visual position indicator.

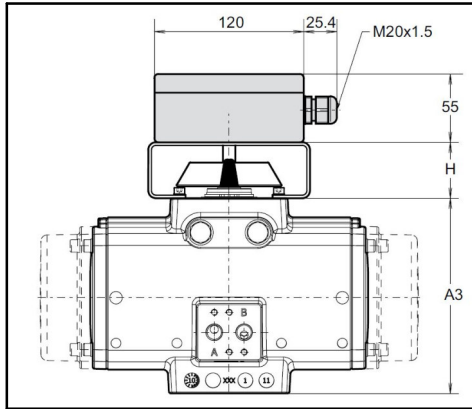

Specific conditions of use

Because the enclosure of the switchbox type LDNA-IS is made of aluminium, if it is mounted in an area where the use of category 1 G apparatus is required, it must be installed such, that even in the event of rare incidents, ignition sources due to impact and friction sparks are excluded. Because the enclosure of the switchbox type LDNA-IS is painted, if it is mounted in an area where the use of category 1 D or 2 D apparatus is required, electrostatic charges on the coated parts of the switchbox shall be avoided.

Dim. In	Actuator model												
	mm.	F12	F25	F40	F65	F100	F150	F200	F350	F600	F950	F1600	F2500
A1 - FS	118	166	192	217	247	304	362	385	476	658	732	877	959
A2 - FD	103	166	192	217	247	235	265	284	356	400	462	550	649
A3	80	91	112	124	131	157	163	201	248	268	302	354	389
A5	60	68	82	92	103	116	124	161	195	239	306	350	400
A6	60	49	55	58	64	69	72	85	102	131	149	170	196
H	45	45	45	45	45	45	45	45	55	55	55	55	55

Ingress protection

The enclosure is ingress proof to IP65 and as such completely dust and water tight.

Certification

The switchbox is certified for use in zones 0, 1, 2, 20, 21 and 22 with all gas and dust groups.

Product marking

ATEX - Zones 0, 1, 2, 20, 21 and 22

Method: Intrinsically safe

Marking:

⊕ II 1G Ex ia IIC T6...T4 Ga

⊕ II 1D Ex ia IIIC T₂₀₀T41°C...T80°C Da

Certificate: DEKRA 18ATEX0079 X

Temperature: -20°C to +80°C

The actual upper temperature may be limited by the application.

See examination certificate or manual for more detailed info.

Specification

Switches

Make: Pepperl & Fuchs
 Type: 2x NJ2-11-N-G
 Voltage: 8 VDC (Ri = 1kOhm)
 Amps (output): Switched, <1mA, Unswitched, >3mA
 Standards: DIN EN 60947-5-6 (NAMUR)
 Switch operation: Adjustable "Switched"

Housing

Material: Aluminium alloy
 Electrical Entry: 1x M20x1,5
 Enclosure: IP65
 Mounting: Acc. NAMUR VDI/VDE 3845, the F12 Actuator has his own bracket

Identification

LDNA-IS4 Aluminium enclosure with 2x Pepperl & Fuchs NJ2-11-N-G

Option

Vestamid housing

supplied, pre-installed cable gland

Clamping and sealing range: 5-9 mm
 Torque clamping nut: 4,5 Nm

Terminal connections

P&F Type: 2x NJ2-11-N-G

